

MOUNTING PROCEDURE**KIT SAVE CARTER
DUCATI HYPERMOTARD 1100****DH1101**WWW.BARRACUDAMOTO.COM**KIT**

X2. PVC HEAD
 X2. SAVE CARTER BASE
 X4. BRACKET
 X2. SPACER 25 MM
 X2. SPACER 54 MM
 X2. BOLT 10X120
 X2. NUT Ø 10
 X4. RUBBER STICKER STRIPES



APPLY THE RUBBER STICKER STRIPES ON THE 4 BRACKET.

FOLLOW THE FIXING PROCEDURE LIKE SHOWN IN THE PICTURE.

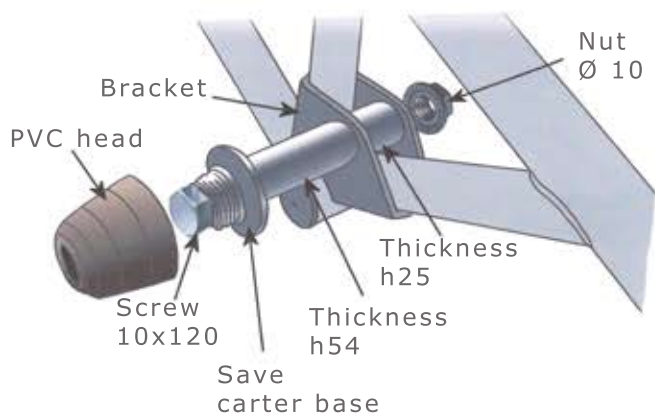
**RIGHT SIDE:**

USE THE BRACKET WITH THE MORE HOLES IN THE INTERNAL SIDE AND USE IT LIKE ACCOMMODATION FOR THE PIVOT FOR THE CABLES (ATTENDANT ON THE CHASSIS).

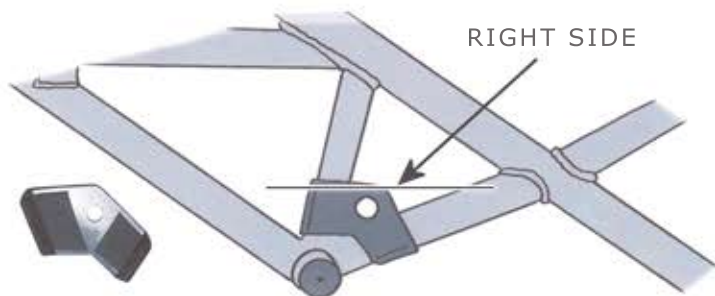

THE FIXING SEQUENCE ABOUT CRASH PAD AND LOCALISATION OF ANCHORAGE IS REPORTED INTO THE PICTURE.

APPLY THE STICKERS RUBBER STRIPES INSIDE THE PLATES TO AVOID DIRECT CONTACTS BETWEEN THE CHASSIS AND THE PLATES BEFORE START TO FIXING; SO TO AVOID ABRASION.

WARNING: RIGHT SIDE: FIND AND DISCONNECT THE ELECTRIC CABLES SUPPORT (ON THE INSIDE SIDE OF MOTORBIKE); USE THE SLAB THAT HAVE A CENTRAL HOLE AND A ONE MORE HOLE TO APPLY ON THE INSIDE SIDE OF MOTORBIKE, WHERE THE CHASSIS HAS THE BRACKET ATTACK FOR THE ELECTRICS CABLES PREVIOUSLY DISCONNECTED